

Telescopic pillar

Telemag TLC

Benefits

- High bending load
- Quiet
- Powerful
- Plug and play

Standards

- EN/IEC 60601-1
- UL 60601-1



Suitable control units and accessories

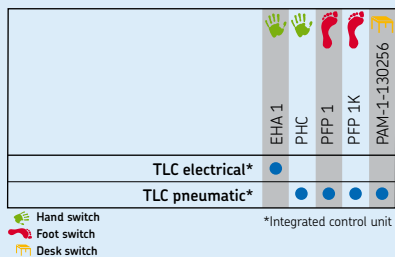

Connecting diagrams

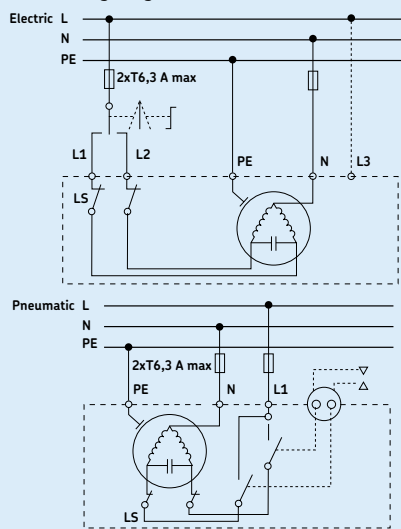

Dimensional drawing

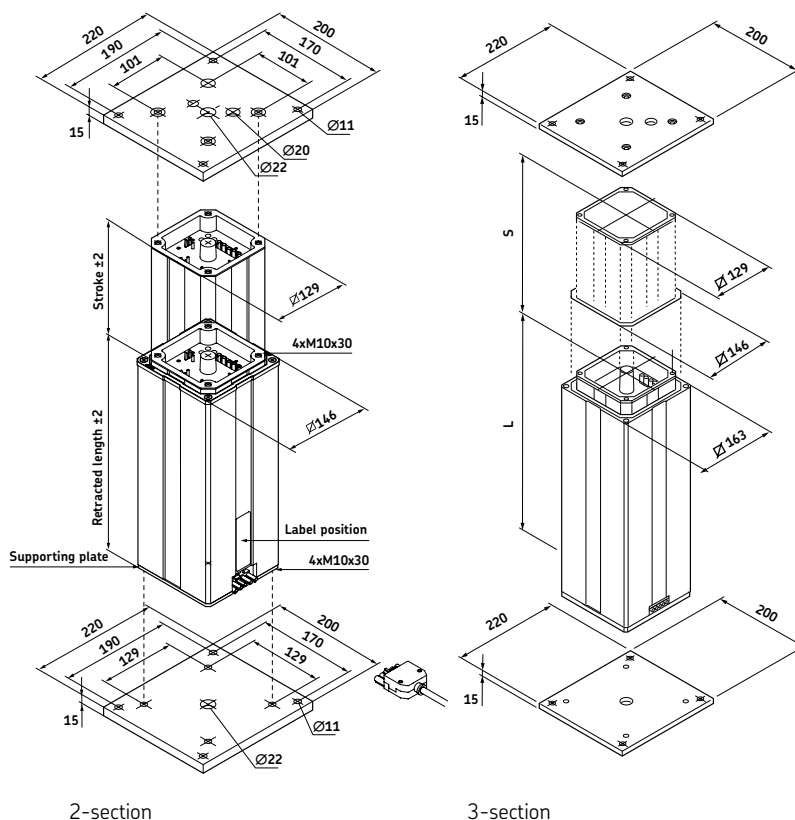

Legend:
 S = stroke
 L = retracted length

Note: mounting plates are not included.
 To be ordered separately.

Technical data

	Unit	TLC 12ZWAS	TLC 12ZWAK	TLC 12ZWDS	TLC 12ZWDK
Push load	N	4 000	4 000	4 000	4 000
Pull load	N	4 000	4 000	4 000	4 000
Max. bending load	Nm	up to 630*	up to 630*	up to 2 100*	up to 2 100*
Speed (full load to no load)	120 V AC 230 V AC	mm/s 16 to 22	mm/s 16 to 22	mm/s 16 to 22	mm/s 16 to 22
Telescopic pillar version	# of section	2-section	2-section	3-section	3-section
Stroke	mm	100 to 700	100 to 700	255 to 700	255 to 700
Retracted length	mm	S+175	S+175	S+60	S+60
Voltage	V AC	120 or 230	120 or 230	120 or 230	120 or 230
Power	120 V AC 230 V AC	W 1 200	W 1 200	W 1 200	W 1 200
Current	120 V AC 230 V AC	A 10	A 10	A 10	A 10
Duty cycle: intermittent operation	120 V AC 230 V AC	min. 0,8 min./37 min.	min. 0,8 min./37 min.	min. 0,8 min./37 min.	min. 0,8 min./37 min.
Duty cycle: short-time operation	120 V AC 230 V AC	min. 1,2	min. 1,2	min. 1,2	min. 1,2
Ambient temperature	°C	+10 to +40	+10 to +40	+10 to +40	+10 to +40
Type of protection	IP	20/30	20/30	20/30	20/30
Protection class	-	I	I	I	I
Type of control	-	electrical	pneumatic	electrical	pneumatic
Weight	kg	15,2-24,5	15,2-24,5	18,3-30,5	18,3-30,5

* For details, please see bending load diagrams

Performance diagram

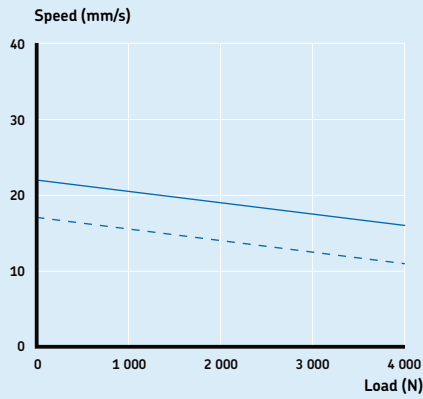

Speed-load diagram

— 120 V AC version
 - - - 230 V AC version

Bending load diagrams

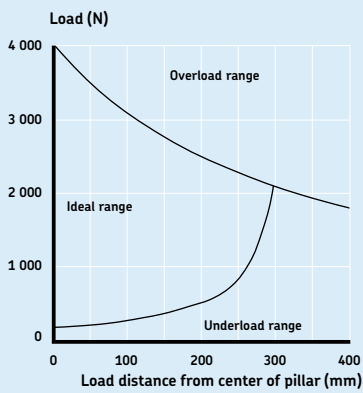

Bending load diagram 2-section

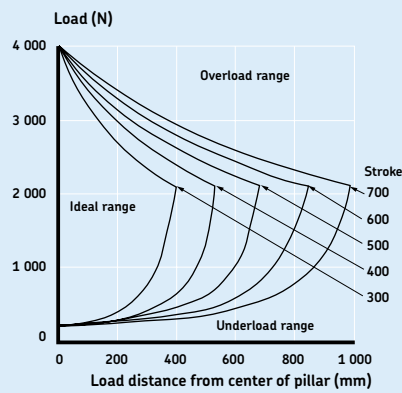

Bending load diagram 3-section

Safety factor load conditions

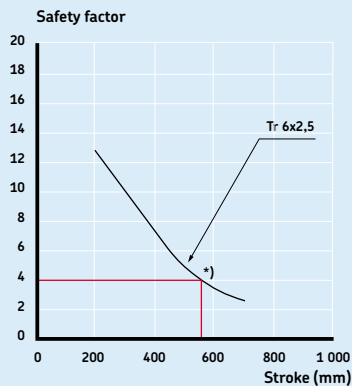

* Safety factor = 4

Ordering key

T	L	C	12		W					-		0	
---	---	---	----	--	---	--	--	--	--	---	--	---	--

Type

Load:

4 000 N
3 000 N
2 000 N

Z
X
S

Tube set:

Tube set 2×
Tube set 3×

A
D

Control:

Electrical control
Pneumatic control
Low-voltage control

S
K
N

Voltage:

230 V AC/50 Hz (no code)
120 V AC/60 Hz
Special voltage

2
9

Type of protection/test:

Standard IP30 (no code)
UL approved

U

Construction:

Push load
Customer-specific
Pull load

0
1
3

Stroke (S):

100 mm, only for tube set 2×, push
255 mm, only for tube set 3×, push
200 mm, only for tube set 2×
300 mm
400 mm
500 mm
600 mm
700 mm

1
1
2
3
4
5
6
7

Options written in italic fonts are only available on demand. Please contact SKF

Accessories

Description	Designation	Order N°
Top mounting plate for 2 × tube set	SPL-290265	M/0125623
Bottom mounting plate for 2 × tube set	SPL-290351	M/0125625
Top mounting plate for 3 × tube set	SPL-290268	M/0125624
Bottom mounting plate for 3 × tube set	SPL-290265	M/0125623
Screw (4/plate) for mounting plate	ZBE-510707	M/0125360
Plug AC Telemag 3 pin	SEL-265518	M/0124866
Plug AC Telemag 5 pin	SEL-265519	M/0124864

© SKF is a registered trademark of the SKF Group

© SKF Group 2009

The contents of this publication are the copyright of the publisher and may not be reproduced (even extracts) unless prior written permission is granted. Every care has been taken to ensure the accuracy of the information contained in this publication but no liability can be accepted for any loss or damage whether direct, indirect or consequential arising out of the use of the information contained herein.

Printed in Sweden on environmentally friendly paper.

PUB L5322,1630 EN · September 2009

